

Shortpass 790 HT - on request

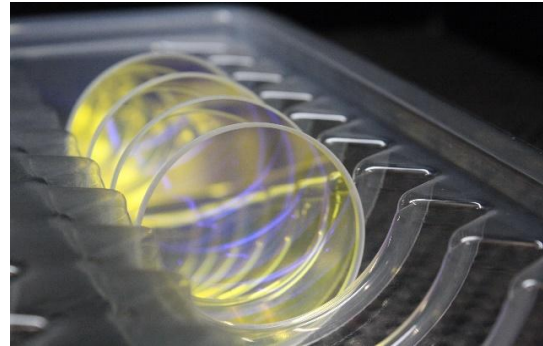

Schneider-Kreuznach magnetron sputtered industrial shortpass filters impress with steep slopes and high transmission at stable cut-off wavelengths. The very flat surface makes them ideal for high end machine vision systems in factory automation. Schneider-Kreuznach shortpass filters are RoHS con-form. Custom sizes are available on request.



Key features	Applications
<ul style="list-style-type: none"> • Average Transmittance 95% • Steep Slopes • Wavelength Tolerance +/- 1% • Ultra Low Refelction • Deep Blocking / High OD 	<ul style="list-style-type: none"> • Metrology • 3D Measurement • Food and beverage inspection • Automotive • Security / Surveillance

Standard Products		available on request	
Name	Description	Name	Description
SP 700 E	absorption filter - IR Cut < 750 nm	SP 460 HT	Shortpass < 460 nm
		SP 515 HT	Shortpass < 515 nm
		SP 615 HT	Shortpass < 615 nm
		SP 730 HT	Shortpass < 730 nm
		SP 760 HT	Shortpass < 760 nm
		SP 790 HT	Shortpass < 790 nm
		SP 850 HT	Shortpass < 850 nm

Shortpass 790 HT - on request

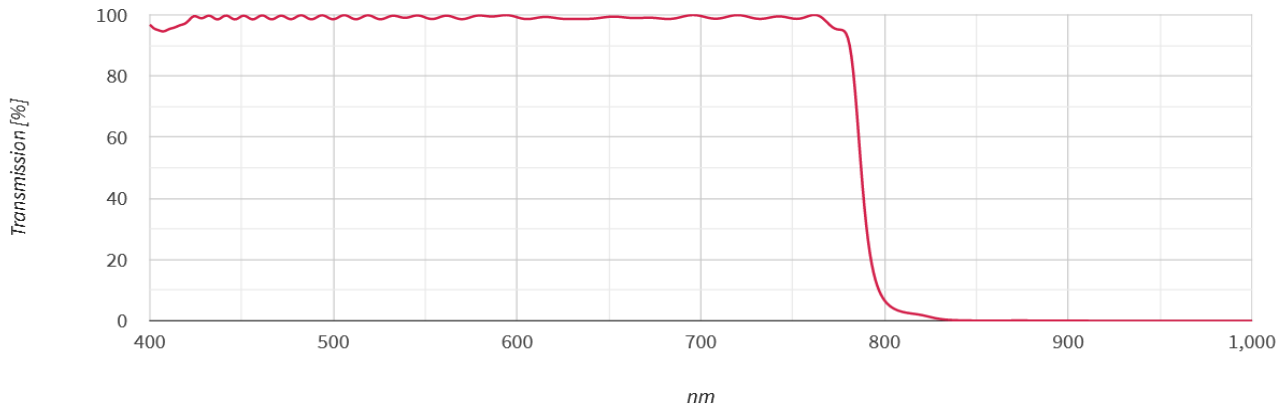

Technical specifications	according to ISO 10110
Angle of incident	0° +/- 8°
Cut-off wavelength	790 +/- 8 nm
Transmittance	425 - 775 nm: $T_{abs} > 90\%$ 425 - 775 nm: $T_{ave} > 95\%$
Blocking	840 - 1050 nm: $T_{abs} < 1.0\%$ 1050 - 1100 nm: $T_{abs} < 2.0\%$
Wavefront distortion	$\varnothing > 18 - 30$ mm: 13/ 1(0.25) $\varnothing > 30 - 50$ mm: 13/ 1(0.30)
Parallelism	1'
Glass thickness tolerance	+/- 0.08mm

C-Mount

Defined by 1" (25.4mm) diameter and 32 turns per inch pitch, the C-Mount thread is a popular camera mount in machine vision industry. Schneider-Kreuznach offers a CMT mount option for most filters. So filters fit in any C-Mount based mechanics, including the C-Mount thread of a camera. The extension of the back flange distance has to be considered for imaging applications.

Key features	Applications
--------------	--------------

- | | |
|---|---|
| <ul style="list-style-type: none"> • Fits in C-Mount cameras • Robust • Black anodized brass | <ul style="list-style-type: none"> • Mounted in C-Mount camera threads • In vision systems based on C-Mount mechanics |
|---|---|

Thread	Diameter	Clear Aperture	Thickness
1" - 32	25.4 mm	21.1 mm	3.6 mm

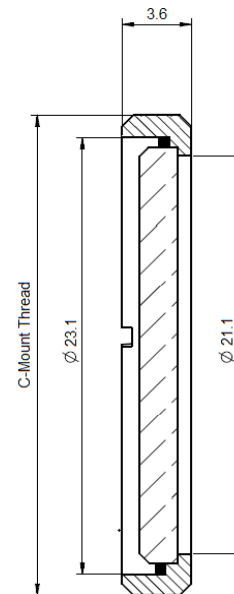

SH-Mount

SH-Mount is the standard thread mount when high flexibility and stability is required. The filter glass is held in place by a retainer ring. SH-Mounts are extremely robust, have a female and male M-thread and can be stacked if several filters must be combined.

Key features	Applications
--------------	--------------

- | | |
|---|---|
| <ul style="list-style-type: none"> • Stackable • Robust • Black anodized brass | <ul style="list-style-type: none"> • Mounted on lenses • Mounted on measurement instruments |
|---|---|

Thread	Diameter	Clear Aperture	Thickness
M 25.5x0.5	27.0 mm	20.8mm	6.4 mm
M 27.0x0.5	28.5 mm	21.8 mm	6.4 mm
M 34.0x0.5	36.0 mm	28.8 mm	6.4 mm
M 35.5x0.5	37.0 mm	30.8 mm	6.4 mm
M 37.0x0.75	39.0 mm	31.8 mm	6.9 mm
M 39.0x0.5	40.5 mm	33.8 mm	6.4 mm
M 40.5x0.5	42.0 mm	35.8 mm	6.4 mm
M 43.0x0.75	45.0 mm	37.8 mm	6.9 mm
M 46.0x0.75	48.0 mm	40.8 mm	6.9 mm
M 49.0x0.75	51.0 mm	43.8 mm	6.9 mm
M 52.0x0.75	54.0 mm	46.8 mm	6.9 mm
M 55.0x0.75	57.0 mm	49.8 mm	6.9 mm
M 58.0x0.75	60.0 mm	52.8 mm	6.9 mm
M 62.0x0.75	64.5 mm	56.8 mm	6.9 mm
M 67.0x0.75	69.5 mm	61.8 mm	6.9 mm

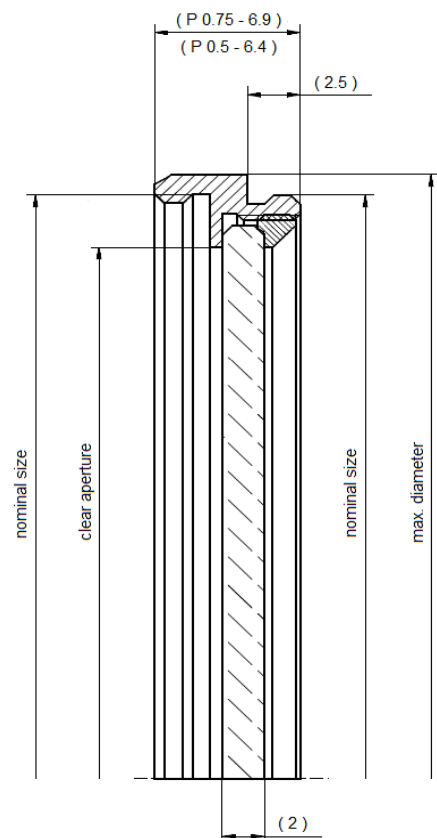

SN1-Mount

The SN1-Mount was designed for the popular M30.5x0.5 thread. With its high clear aperture, vignetting can be avoided even for wide angle applications. The filter is glued into the mount. So it is secured against vibrations when integrated into robots or production lines. It is ideal to be used in automated fabrication. SN1-Mounts have a male and female M-thread and can be stacked if several filters must be combined.

Key features	Applications
<ul style="list-style-type: none"> • Maximum clear aperture • No vignetting • Stackable • Robust • Black anodized brass 	<ul style="list-style-type: none"> • Mounted on lenses • Mounted on measurement instruments

Thread	Diameter	Clear Aperture	Thickness
M 30.5x0.5	32 mm	28 mm	6.5 mm

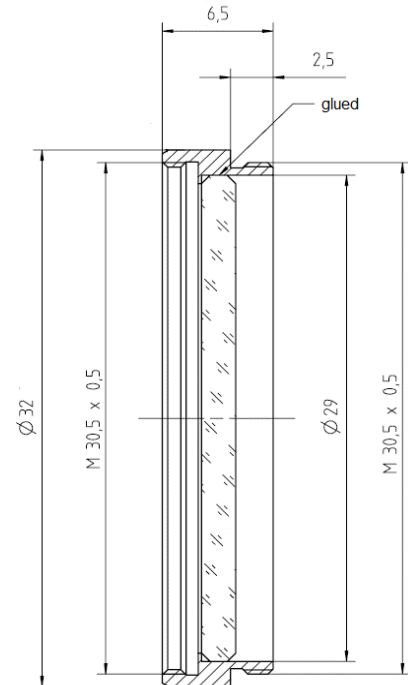

Headquarters Europe

Jos. Schneider Optische Werke GmbH
Ringstraße 132
55543 Bad Kreuznach
+49 671 601 205
isales@schneiderkreuznach.com
www.schneiderkreuznach.com

Offices Worldwide

America

+1 800 645 7239 (East Coast)
+1 800 228 1254 (West Coast)
info@schneideroptics.com

Asia

+86 755 8832 1170
info@schneider-asiapacific.com